



Planning and Zoning Board Agenda

July 24, 2025

6:00 P.M.

Joel Huneycutt Community Room

Chairman: Tim Fesperman

Board Members: James Baucom, Amanda Pasquarello, Jeff Claiborne, Chuck Cowherd, Joseph Abbatiello, Jason Eury, and Matthew Sanford

Alternates: Sharell Salzedo and Jarvis Williams

Call to Order:

1. Call to Order
2. Presentation of Colors
3. Prayer
4. Adopt Agenda
5. Approval of Minutes
6. Public Comment Period: 30 minutes set aside

Old Business:

New Business:

7. Greater Life Church - Conditional Rezoning
8. Chairman's Report
9. Board Closing Comments
10. Adjourn



Locust Planning & Zoning Board

Meeting Minutes

6:00 PM

Joel Huneycutt Community Room

May 22, 2025

Board Chair
Board Members

Tim Fesperman
James Baucom, Amanda Pasquarello, Jeff
Claiborne, Chuck Cowherd, Joseph
Abbatiello, Jason Eury, and Matthew
Sanford

Alternates: Sharell Salzedo and Jarvis
Williams

1. Call to Order

Meeting was called to order at 6:00pm

2. Presentation of Colors, Prayer

Board Chair Tim Fesperman led in the Pledge of Allegiance and P&Z Director Scott Efird gave the invocation.

3. Adopt Agenda

M/S/A Board Members Joe Abbatiello and James Baucom (8-0)
Motion to adopt the agenda as presented

4. Minutes - adopt March 27, 2025

M/S/A Board Members Jeff Claiborne and Joe Abbatiello (8-0)
Motion to approve March 27, 2025 minutes

March 27, 2025

5. Public Comment Period

No one signed up to speak

6. Old Business

7. New Business

The conditional re-zoning request for Rock Therapy, 124 Laurin Ct, Locust NC, was presented by Zack Fraychineaud. This is an indoor rock climbing gym and recreational facility. They currently have a mobile rock climbing unit that they bring to all of our events and is very widely used and enjoyed. The board reviewed the proposed site plan, elevations, and materials.

M/S/A Board Members James Baucom and Matthew Sanford (8-0)

Motion to send a favorable recommendation to the City Council for the conditional rezoning request submitted by Rock Therapy.

Rock Therapy Conditional Rezoning

Site Plan

Elevations

8. Chairman's Report

Papa John's is coming to Locust in the strip building between Starbucks and Jersey Mikes. Cookout and Caliber Corner were both approved by Council.

9. Board Closing Comments

No comments at this time.

10. Adjourn

M/S/A Board Members James Baucom and Joe Abbatiello (8-0)

Motion to adjourn at 6:35pm

Amy Furr, City Clerk

Tim Fesperman, Board Chair

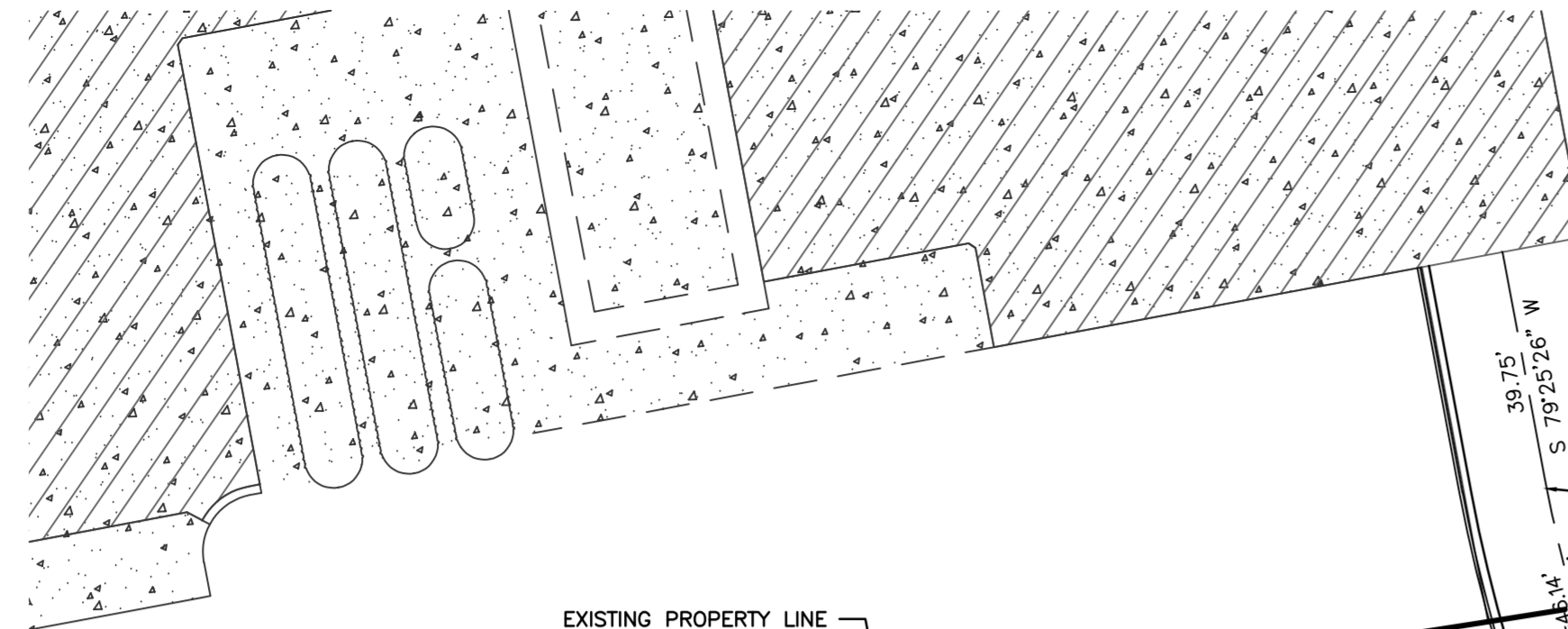
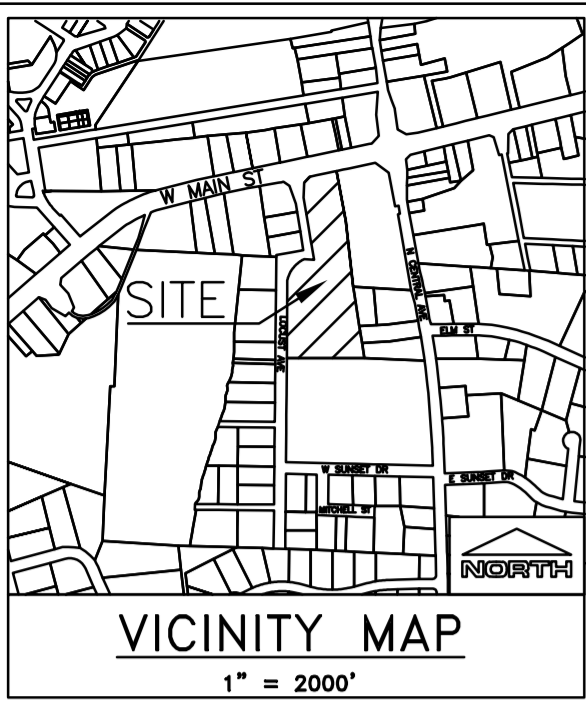

N/F
Locust Fire Department, Inc.
PIN: 357500414684
DB: 253, P: 492
Zone: CC

Locust Volunteer
Fire Dept.
DB: 61
Zone: 20

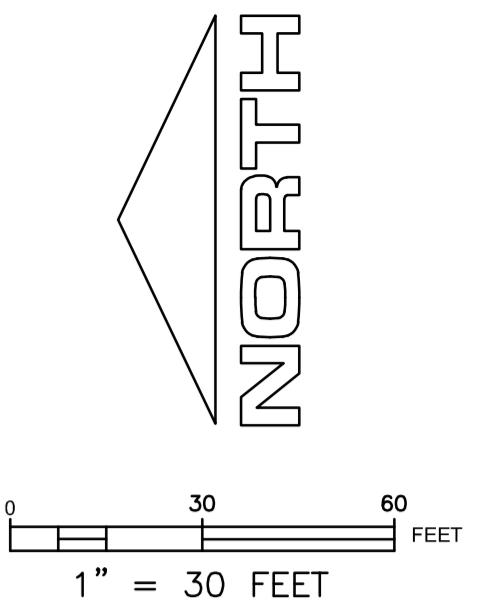

EXISTING BUILDING

PROPOSED FUTURE BUILDING

FUTURE CHURCH BUILDING TO BE BUILT AT LATER DATE

PROPOSED LOT TO CONNECT TO FUTURE QT THROUGH EASEMENT ACCESS

PROPOSED CROSSWALK

STORMPOND

RELOCATED HOUSE WITH DRIVEWAY

PROPOSED DRY POND
SEE SHEET C310

20' SIDE SETBACK, TYP.

PROPOSED LANDSCAPE BUFFER

EXISTING PROPERTY LINE

